

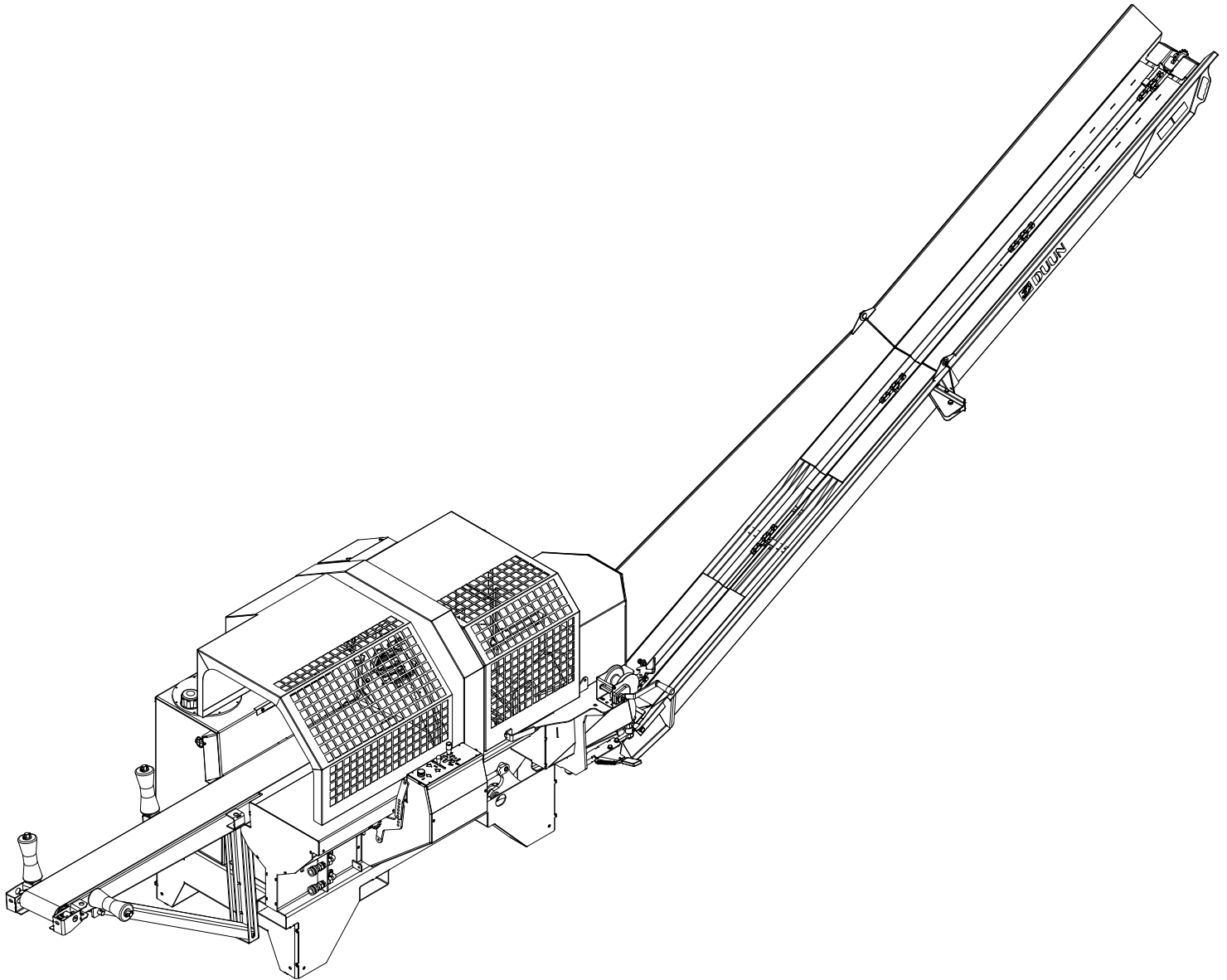

Duun Industrier as  
7630 Åsen, Norway  
[www.duun.no](http://www.duun.no)

# Fire wood processor VM370

## Instruction manual



Congratulations with your Duun VM370 firewood processor.

All Duun tractor operated machines has been engineered and tested in close cooperation with end users of our products. This in order to develop reliable and user friendly machines

Please red instructions manual before you start using the machines..

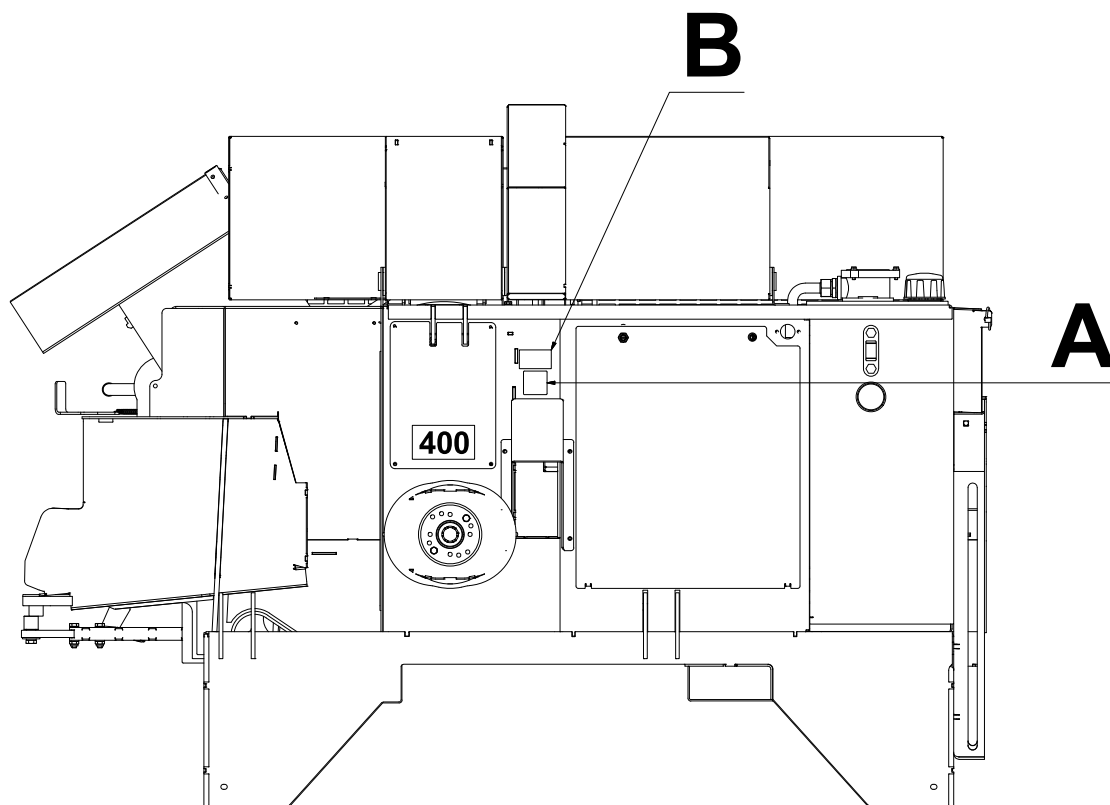

## Machine identification

Serial number and manufacturer should be indicated at badge (A)

Register serial No and time of delivery as indicated.

Do always specify serial number every time requesting service for the machine.

The machine has a CE-badge (B) this confirms that the machine has been manufactured in conformity with: Directive 2006/42/EC Machinery.

---

Serial number

---

Time of delivery (month-year)

Innholdsfortegnelse

<u>MACHINE IDENTIFICATION</u>	<u>2</u>
<u>SAFETY</u>	<u>4</u>
<u>WARRANTY TERMS</u>	<u>9</u>
<u>DELIVERY FORM FOR DUUN VM420 FIREWOOD PROCESSOR</u>	<u>10</u>
<u>SPECIFICATIONS</u>	<u>11</u>
<u>PREPARATION FOR USE</u>	<u>13</u>
<u>PRACTICAL USE</u>	<u>17</u>
<u>CHAIN SHARPENING AND TIGHTENING</u>	<u>22</u>
<u>SERVICE AND MAINTENANCE</u>	<u>25</u>
<u>DECLARATION OF CONFORMITY</u>	<u>29</u>

# SAFETY

All operators, mechanics and the owner must be well acquainted with the instruction in this instruction manual before the machine is taken into use.

You should always work with care when you employ agricultural machinery. Read and observe the safety instructions in this binder. Your safety is your responsibility!



Be particularly aware of warning signs with this symbol it marks measures that must be carried out in order to avoid accidents. The symbol appears in the instruction manual and on warning signs on the machine.

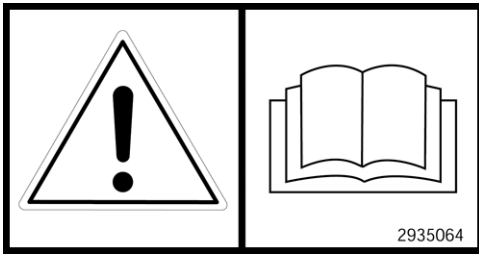

## Instruction manual

All operators, mechanics and the owner must be well acquainted with the instruction in this instruction manual before the machine is taken into use.



## The safety of the surroundings

Make sure that no-one not concerned are present in the area of work. We emphasize as strongly as possible that only one person is to handle the machine, i.e. operate the saw chain sword and the splitter. Nobody is to assist the main operator in the work area - risk of injury! Never start the machine when there are people or animals close to the machine or the tractor. Never stand between the tractor wheels and the machine!

If other persons than the operator of the machine are present in the risk zone, the operator is to explain the danger the machine involves!

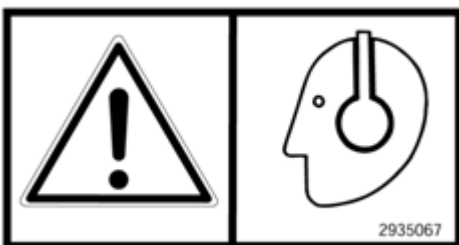

## Personal protection equipment

You should always wear hearing protection and protective goggles when using the wood machine. Further, you should use protective footwear and sturdy work gloves during handling of the machine and the materials.



### **Clothing and the drive shaft**

Do not work in clothing that may be caught in the moving parts of the machine (for example scarf, wide coats).

The tractor must be disconnected and the hand brake activated before the shaft is connected to the tractor's power take-off. The drive shafts are always to be equipped with original protection covers.

### **Damaged and worn covers are to be replaced immediately!**

Make sure that all covers for the shaft are in good condition and correctly fitted. Never start the machine when this is not in order. The locking chains for the plastic covers are always to be fixed to the appropriate brackets in order to prevent the covers to rotate.



### **Safe connection and use.**

Allow nobody to stay between the machine and tractor when the machine is connected to the tractor. The same applies during use of the machine. Make sure that the connection is carried out in a safe manner.

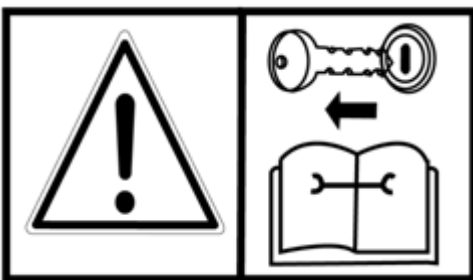

### **6. Safety in case of interruptions and maintenance.**

Remember always to stop the tractor's engine and remove the ignition key before you lubricate, adjust, clean or carry out repairs. This is to secure that the tractor does not start before you have completed the operation.

### **Hydraulic high fluid pressure.**

Be careful when you work with hydraulics. Wear eye protection and gloves. Hydraulic oil under great pressure may penetrate the skin and cause serious infections. See a doctor if you have had an injury. Ensure that no-one is standing close by when hydraulic functions are performed.

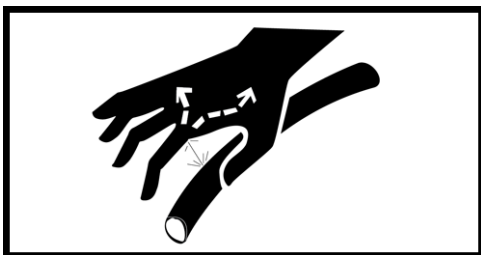

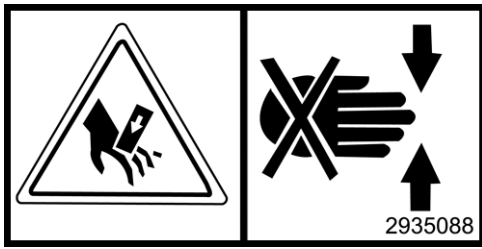

### Rotating parts – risk of crushing

The machine's rotating parts may cause severe injuries. The same applies to risk of crushing during operation.

All covers and protective equipment is to be fitted on the machine during use. The user is responsible if an accident occurs as a consequence of defective protection.

Avoid all unnecessary stay in the working area when the machine is in operation.

Never put your hand in behind the protective screen even if the saw chain is in back position



### Zero alcohol tolerance

Persons who are under the influence of drink or drugs must not operate the machine. The same applies to tired people who do not have full control over their movements.

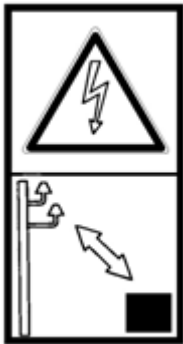

### Contact with electric wires and similar during transport.

Be aware that the wood machine may be taller than the tractor during transport and there is a risk of contact with electric wires, railroad underpasses etc!

If the machine has been set up for splitting of 60cm wood lengths, it should be set back to 40cm before moving. This is because the machine will protrude on the right side if it transported in "60cm set-up". If you choose to move the machine in "60cm set-up", you should be very attentive of the fact that there is a protrusion beyond the width of the tractor on the right hand side



### Conveyor – conveyor belt

Avoid staying under the transporter when this is under tension in order to avoid injuries in case of any uncontrolled downfall during use. Also avoid contact with the transporter's moving parts during use.

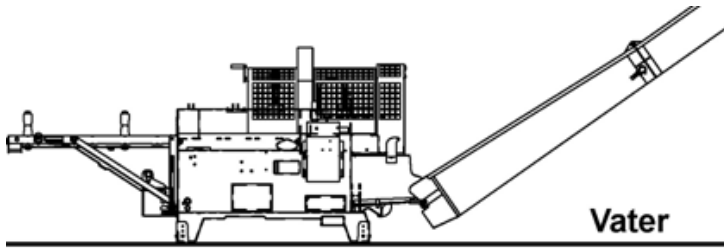

**Horizontal positioning and tidiness on the workplace**

Always place the machine as horizontally and steady as possible to secure stable working conditions.

Keep the workplace as tidy as possible. This contributes to generally better safety against unwanted events.

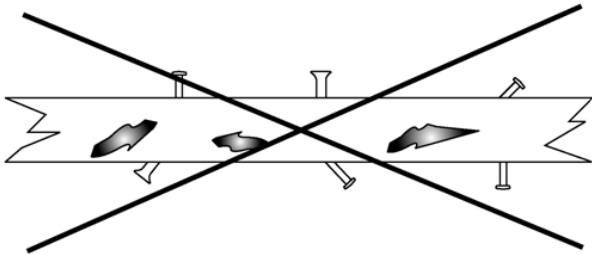

**Area of application**

The machines are only intended for production of fire wood from "pure" wood material without any contaminants. It is not allowed to employ the machine for other material such as construction waste and similar with metal parts such as nails, screws and similar. The same applies for materials that are polluted with plaster and similar coatings. The saw chain is only designed for wood materials without contaminants.

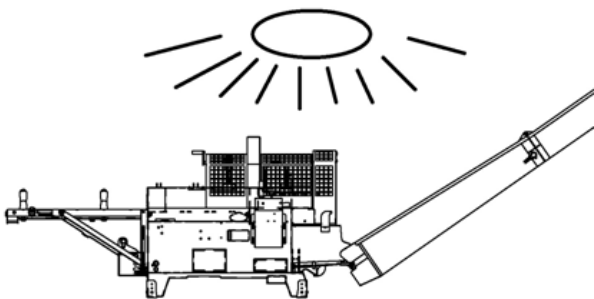

**Good lighting – a necessity.**

The machine must only be used in daylight that secures a good overview of the operations – or with artificial lighting which provides good overview of the work area.

Good lighting is very important with reference to safety.

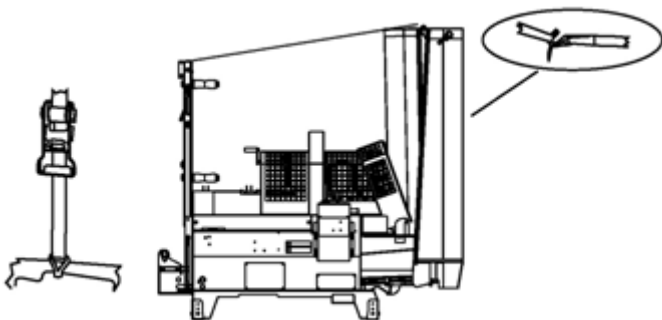

**Safe transport**

Before the machine is moved, the feeder conveyor and transporter (both in an up-right position as outlined in the illustration) are to be strapped to secure that they do not fall down. The loading strap has a fixing point at the lower part of the feeding conveyor and secures the conveyor belt from falling off during transport

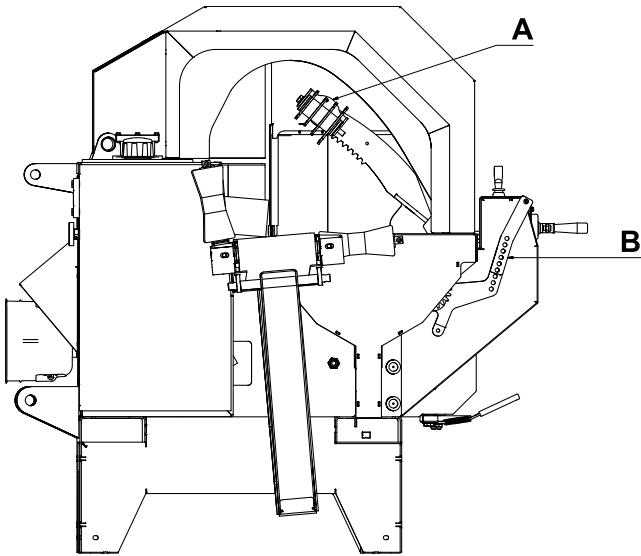

### **Safe cutting**

Avoid placing your hands close to the saw chain. This is obtained by consequently using the log holder A and the handle B to operate it.

For cutting the last log of wood, it is important to retain a “suitable” length and cut a shorter piece as the next to last..

You are advised to use the “count-down ruler” for the last three lengths so that these may be cut to a somewhat shorter even length than the desired length.

When you want to cut twiggy or crooked logs, it is important to make sure that these are securely placed.

Before start-up after maintenance you should check that all tools have been removed and brought back into place.

Before the machine is elevated or lowered, you should check that no-one is close to or touch the machine.

**If any warning signs are removed during repair or service, new signs must be fitted**



## Warranty terms

Fire wood processor VM370 has a 12 month guarantee against defects in materials and workmanship.

Parts that are not originally manufactured by Duun Industrier AS, for example shafts, bearings etc. are subject to these suppliers' guarantees and terms.

Parts that are considered to be wear parts are not part of the basis of the guarantee - these have been specified in a separate survey on the bottom part of this page.

In cases where a repair is considered to be covered by the guarantee, the representative must inform the supplier's representatives that the repair is intended executed on the basis of the guarantee.

In this context, the following information must be recorded:

- Product name
- The product's serial no. (see the machine identification pp. 6 and 7]
- Date of sale
- The product owner's telephone no.
- Dealer with address, telephone no.

In case of such a repair, the supplier is presented with a claim within 3 weeks after the repair date.

Replaced parts are to be kept until a decision has been made with reference to the claim and the replaced parts are to be forwarded to Duun Industrier for assessment if so required.

As the employment of the product is beyond our control, we may only guarantee the quality and do not accept liability for the product's general performance.

The guarantee liability assumes that the prescribed maintenance has been carried out.

Duun Industrier reserves the right to modify the design and specifications and/or make alterations and improvements without notification.

What is not included by the guarantee

- The guarantee does not cover economic loss as a consequence of interruptions.
- The guarantee does not cover consequential loss due to defects.
- The guarantee does not cover defects or damage caused by misuse and use that is not in accordance with the instruction manual's specifications and guidelines.

**The following parts and material are considered as wearing parts and are not covered by the guarantee:**

- The chain saw bar
- The saw chain
- The wood splitter knives
- The feeding belt
- Oil filter
- Hydraulic oil
- Filter cartridge for hydraulic oil
- Wear parts in splitting mechanism

# Delivery form for Duun VM420 firewood processor

## Machine specifications

Model \_\_\_\_\_

Serial No.. \_\_\_\_\_

## Customer details

Machine owner \_\_\_\_\_

Address \_\_\_\_\_

Aip code. \_\_\_\_\_

Town \_\_\_\_\_

## Hand over of machine

Sales representative and customer have controlled that the machine do not have any transportation damages and that specified equipment is delivered..

The customer has been instructed how to use the machine:

- How to prepare machine for use from transport position. (page 14 and 18)
- Height adjustment of machine and correct length of pto to reduce strain (page 13)
- from too steep angle between tractor and processor (page 14)
- How to control temperature and oil level. (page 17)
- How to control eventual condensation level in oil tank (page 17)
- What is correct pto speed (page 17)
- The machine functions.
- Feed belt: Speed adjustment (page 18)
- Use of "remote" control
- Cutting : Adjustment of saw movement speed and power (page 18)
- Sharpening and tightening of chain. (page 21-23)
- Adjustment of chain greasing (page 23)
- How to use log clamp. (page 19)
- Splitting: How to use handle for forced return (page 20)
- Elevation of splitting knives and change og splitting knives (page 19)
- How to switch from 40 to 60cm splitting length and vice versa. (page 16)
- Conveyor: Speed adjustment (page 18)
- Sideward movement of conveyor. (page 20)

Sales representative and customer have read about service and maintenance (page 24-28).

The customer has been introduced to warranty terms (page 8)

The customer has been introduced to conditions for practical use (page 17)

Part list is available at sale representative.

Place \_\_\_\_\_

Date \_\_\_\_\_

Customers signature

Sales representatives signature

\_\_\_\_\_

\_\_\_\_\_

## Specifications

Feature	VM370	VM370X
Cutting diameter max	37 cm	37 cm
Max splitting force	7000 kg	8500 kg
Chain drive	Hydraulic	Hydraulic
Log length	20-50 cm stepless	20-50 cm stepless
Saw chain type	1,6 mm	1,6 mm
Chain speed	23 seconds metre	23 seconds metre
Size saw chain	0,325" deling	0,325" deling
Saw chain links total	78 links	78 links
Weight	Ca 880 kg	Ca 880 kg
Moving log stop?	Yes	Yes
Height of work table	880-960 mm	880-960 mm
Support legs	Asseccory 0-40-80 mm	Asseccory 0-40-80 mm
Splitting knife	4-part frame mount	6-part frame mount
Rinsing conveyor	Yes	Yes
Saw chain lubrication	Separate pump	Separate pump
Knife adjustment	Manual	Hydraulic
Number of hydraulic pumps	2	3
Feeding belt A	Hydraulic	Hydraulic
Conveyor length B	4000 mm	4000 mm
Conveyor movement sideways D	25° each side	25° each side
Maximum height E	2540 mm	2540 mm
Maximum width C	2400 mm	2400 mm
Depth transport position	1500 mm	1500 mm
Saw chain oil container	2,5 liter	2,5 liter
TPM's at pto	400 rpm	400 rpm
Hydraulic oil volume	75 liter	75 liter

Asseccories	Item numbers
4-part splitter	14131128
6-part splitter	14131035
Adjustable support legs	141309131
Triangel quick connect	1252637
HMV quick connect	1252638
Log rack manual	141409001
Log rack hydraulic	141409002

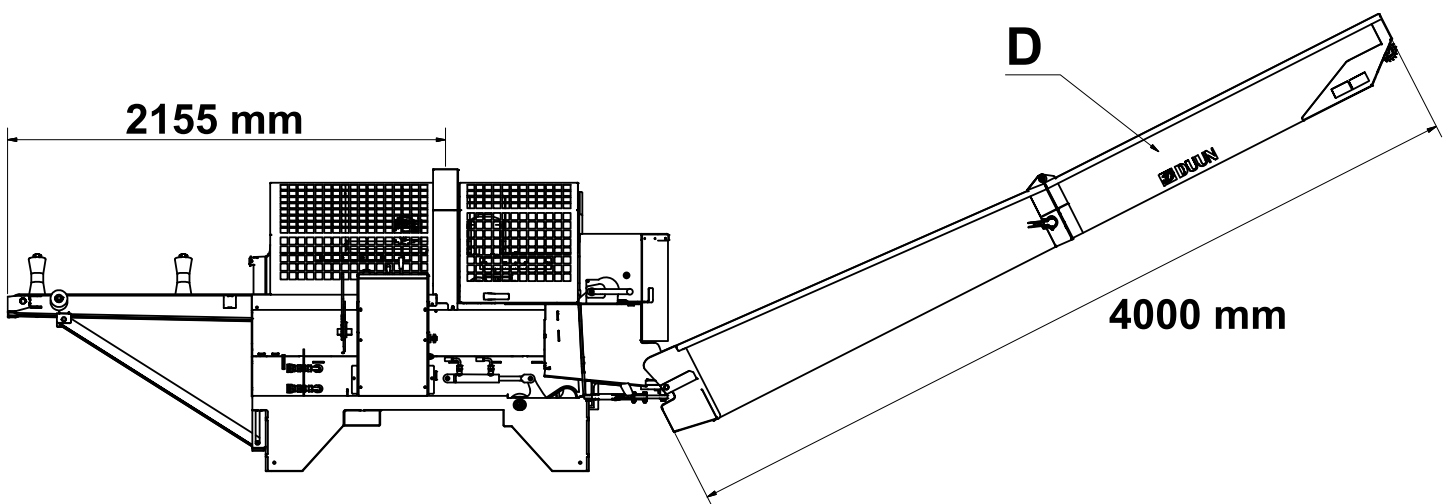
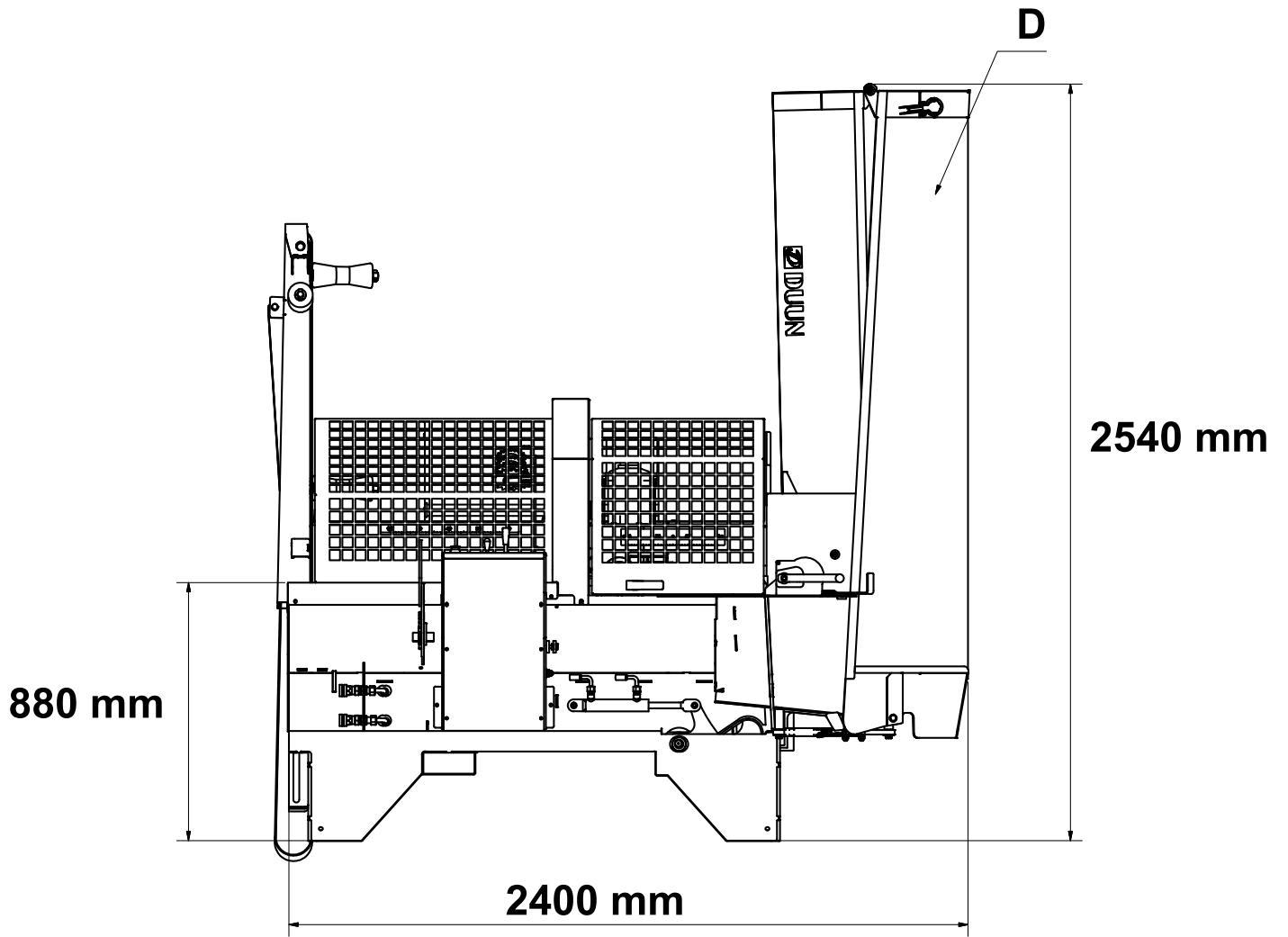

## Preparation for use

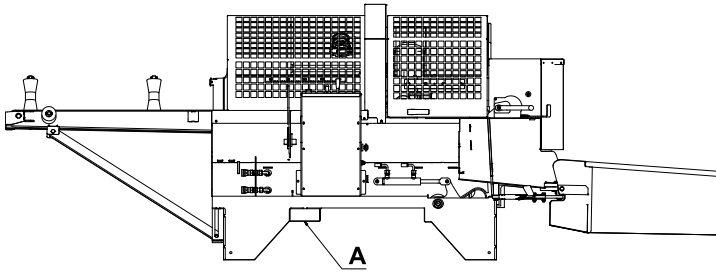

### Transport and handling before use

The VM420 body is equipped with a fork pocket (A) for handling with fork truck or pallet forks. Be aware that one individual wood machine weighs about 875 kg. Use lifting equipment designed for such total weight

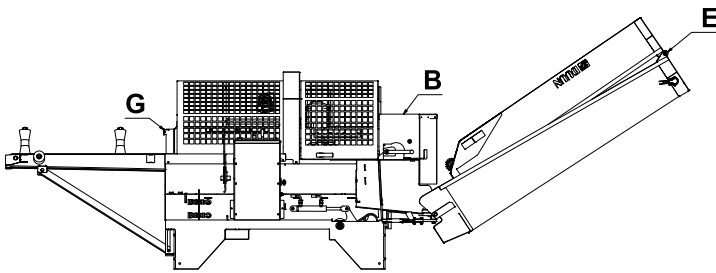
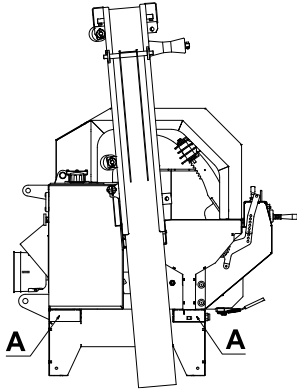

### Preparation for moving with tractor.

The transporter is folded together in the joint E. Afterwards, the transporter is moved to an upright position by means of the winch wire. During this process, the protection cover is shifted in point B Feeding table and the conveyor belt is adjusted to a vertical and horizontal position by releasing the locking pin in point G

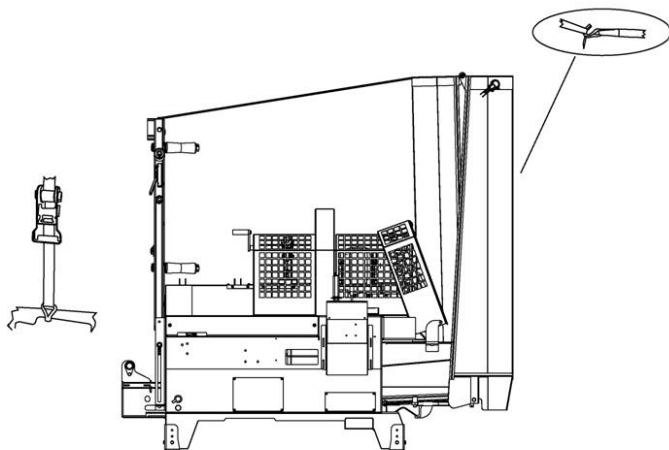

### Securing before moving

Finally, the connection between the feeding table and the transporter should be secured by means of a strap for this purpose with fixing points as shown in the illustration. This is important to ensure that the feeding conveyor is kept in place during transport and the connection between the feeding table and the transporter is safely secured.

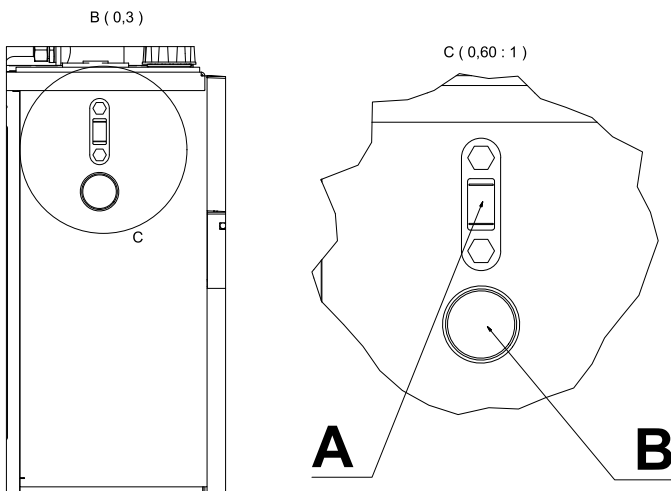

## Hydraulic oil - quality.

The machine's performance will, to a high degree, depend on keeping the hydraulic oil intact. The greatest elements of risk for the quality of the oil are

- Excessively high temperature which entails poor lubrication performance and risk of faults and break-down of expensive components such as valves, pumps and motors.
- Condensation which is formed during conditions including humid air combined with temperature fluctuations. (the oil tank breathes through the filter and sucks in humid air)
- Condensation water in the oil has the same effect as excessively high oil temperature. Condensation appears mainly during use in conditions involving humid air and temperature around 0°C. The oil tank is equipped with a draining plug for changing oil and checks for condensation

## Oil level check.

The machines are filled with 78 litres hydraulic oil from the factory. Recommended oil quality is ISO VG46 (viscosity group 46). Examples of such oils are Ambra Hydrosystem 46 HV, Mobil DTE15m, Statoil Hydraway HVXA46.

The oil level must be checked by observing the sight glass A which is fitted in the suction grille for the hydraulic oil tank.

## Oil temperature check

It is very important to keep track of the oil temperature B and avoid situations where it exceeds 70 degrees. This situation may occur during unfavourable operating conditions for example in case of too high rotational speed during use. The pto speed should under no circumstances exceed 400 rpm

The processor has a built in temperature control device cutting off machine functions if the oil temperature goes too high. Stop the machine and cool off before further operation.

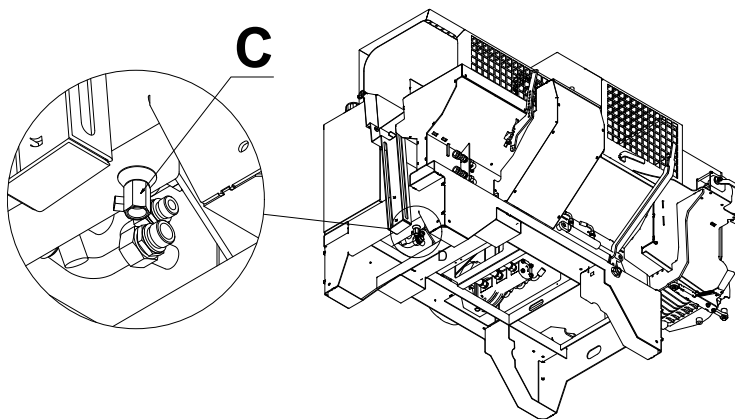

## Condense check

The oil tank is equipped with a drainage plug C in the bottom. Grey oil is an indication of water in the oil. In case the oil is polluted with water, all the hydraulic oil must be changed.

Beyond such conditions, the hydraulic oil must be changed every year or after 500 operating hours (whatever occurs first).

## **Drive shaft**

The requirement for the length of the drive shaft will vary in pace with the size of the tractor and the length of the steady-braces.

If there are operating angles from 25 degrees and upwards, you should employ a category 6 shaft to ensure long service life.

If there are great angles, it might be advantageous either to lower the tractor or elevating the machine. It may be elevated by means of the supporting legs which is standard equipment fitted in the corners and elevate the machine up to 80mm.

Ensure that the pto shaft had sufficient length. The profile tubes in the shaft are to, after any cutting, overlap by half the tube length. Any cutting of the shaft must be executed in accordance with the instructions for such operations – the cut must be trimmed for burrs both on the inside as well on the outside and the profile tubes should be well greased. Too short telescope length of the shaft entails a risk of overload of the tractor's power take-off and the gearbox of the VM420.

Please lubricate the PTO drive shaft before use.

The locking chains for the plastic covers are always to be fixed to the appropriate brackets in order to prevent the covers to rotate.

The drive shaft must be maintained and used in accordance with its instruction manual.

In order to obtain better operating angle, you may let the machine stand by itself and place the tractor at a distance and employ a longer drive shaft during operation.

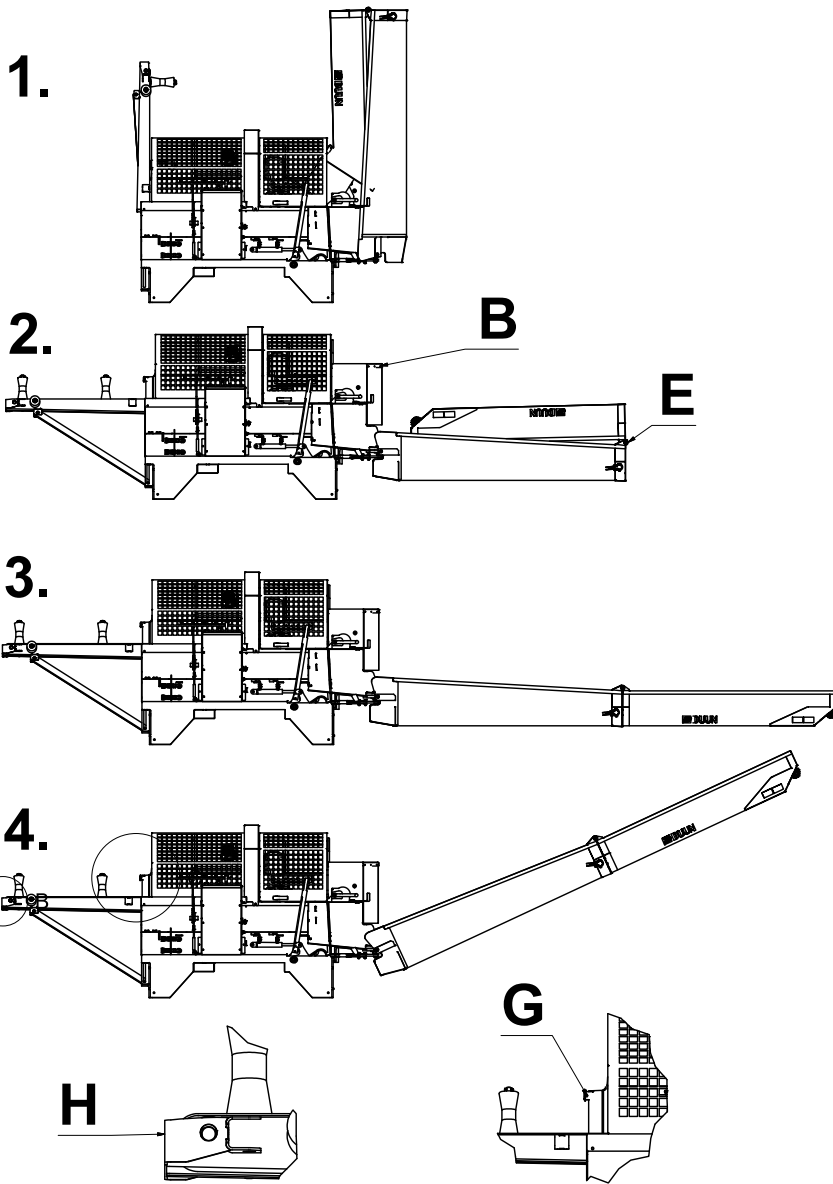

## Preparation for transport.

Preparing for transport by

1. Releasing the strap fixing point and loosening the strap at the points outlined in the illustration.
2. The transporter is put in place by releasing the winch and the wire which holds it in place – the transporter will fold out until it is level with the ground.
3. Afterwards, the transporter is folded out in its full length in the joint E.
4. The transporter is elevated to the required height by means of the winch.

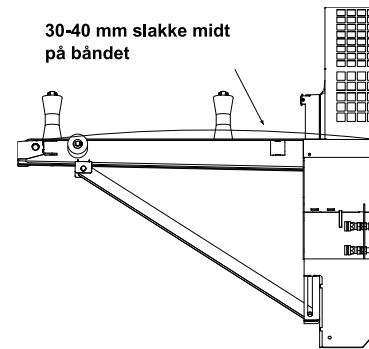

## Preparation of the feeding conveyor

The feeding conveyor is folded in place by releasing the locking pin at letter G which locks it. The belt is tensioned by adjusting the screws at letter H. The belt is sufficiently tensioned if it feeds in the wood without friction. Too hard tensioning increases the wear of the belt and reduces the service life considerably.

An indication of what is suitable tensioning is when the belt in the middle of the feeding table, allows for 30-40mm – Re. Illustration 4, letter I.

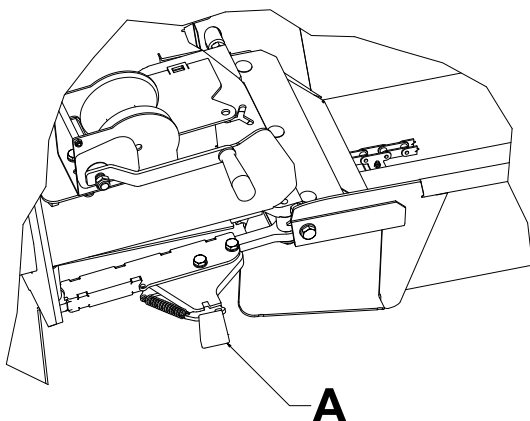

## Sideways adjustment of conveyor

The conveyor can be fixed in three positions at each side that is totally 7 positions. In order to loose the lock the handle A must be moved. The conveyor is now release for sideways movement. The handle A will grip the first vacant position available and lock the conveyor sideways. If wanted to move to the utmost position m Hvis man ønsker å "sideregulere" til ytre posisjon, er det hensiktsmessig å bevege transportøren sideveis til første stopp og så løse håndtaket A for å komme til neste posisjon.



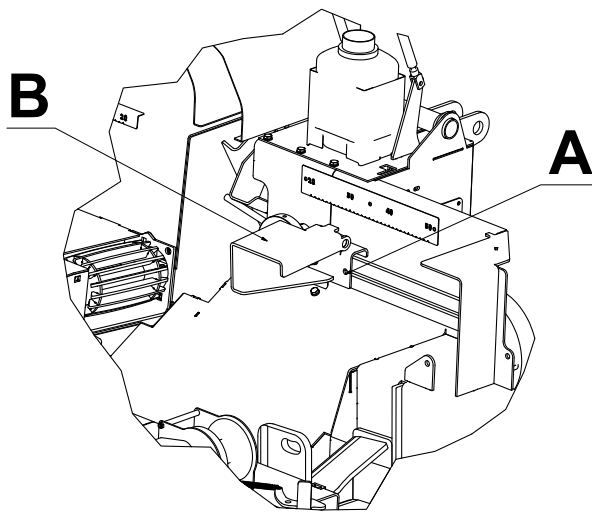

### Adjustment of cut length

The cut length can be adjusted by loosening the screw **A** and adjust the stop point **B** to wanted length.

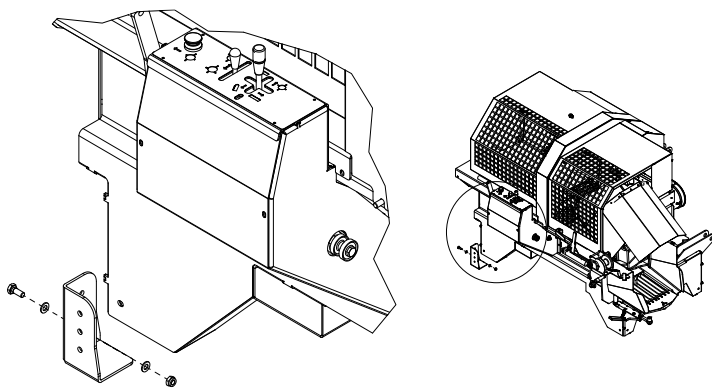

### Adjusting machine height

For eventually elevating the machine in intervals of 40mm up to 80mm the support legs in each corner can be adjusted.

Adjustable legs are extra equipment.  
Our item No.: 141309131

## Practical use

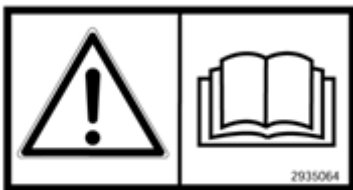

### Condition

The machine **may not be used** before the operator has done the following:

- Has read the instruction manual and knows how the machine works and how to operate it.
- Has made himself acquainted with and observed the information regarding safety described on pages 8 to 12 in the instruction manual.
- Employs suitable clothing; i.e. hearing protection – protective goggles – protective footwear – work gloves.
- Does not use clothing that may be caught in the moving parts of the machine (for example scarf, wide coats).

**If any faults occur in the functions of the machine during employment, the machines is to not to be used before the defects have been repaired.**

Maks. hastighet p.t.o.

# 400 omdr.

2935131

## Start-up and suitable rotating speed – 500 – 540 rpm

The power take-off of the tractor is connected at low rotating speed and increased slowly to 540 rpm which is the max rotating speed of the pto. In order that the machine is to work at its optimum, the rotating speed must be between 500 and 540 rpm.

At lower speed, some functions will receive too low oil pressure.

Let the machine run for some minutes before you start the hydraulic functions

## Activating electric control

The processor is equipped with electric controlled valves for splitter, saw motor and safety functions

Connect the cable delivered with the machine to the socket marked A and to the tractors 12v outlet. Other 12v electricity sources like the tractors 12v battery can also be used as power source.

When starting the machine or every time the electricity supply is cut, the lid (B) covering the splitter must be opened and closed for activating the electric control..

## Main functions – feeding – speed adjustment of the feeding conveyor

The wood material that is to be cut is fed by means of the feeding conveyor.

The main functions are

- A.** To move the feeding belt forwards/backwards.
- B.** Operate the cutting sword up and down.
- C.** Releasing the splitting blow.

It is important that the feeding until the stop is carried out in a moderate speed so that the logs do not bounce back.

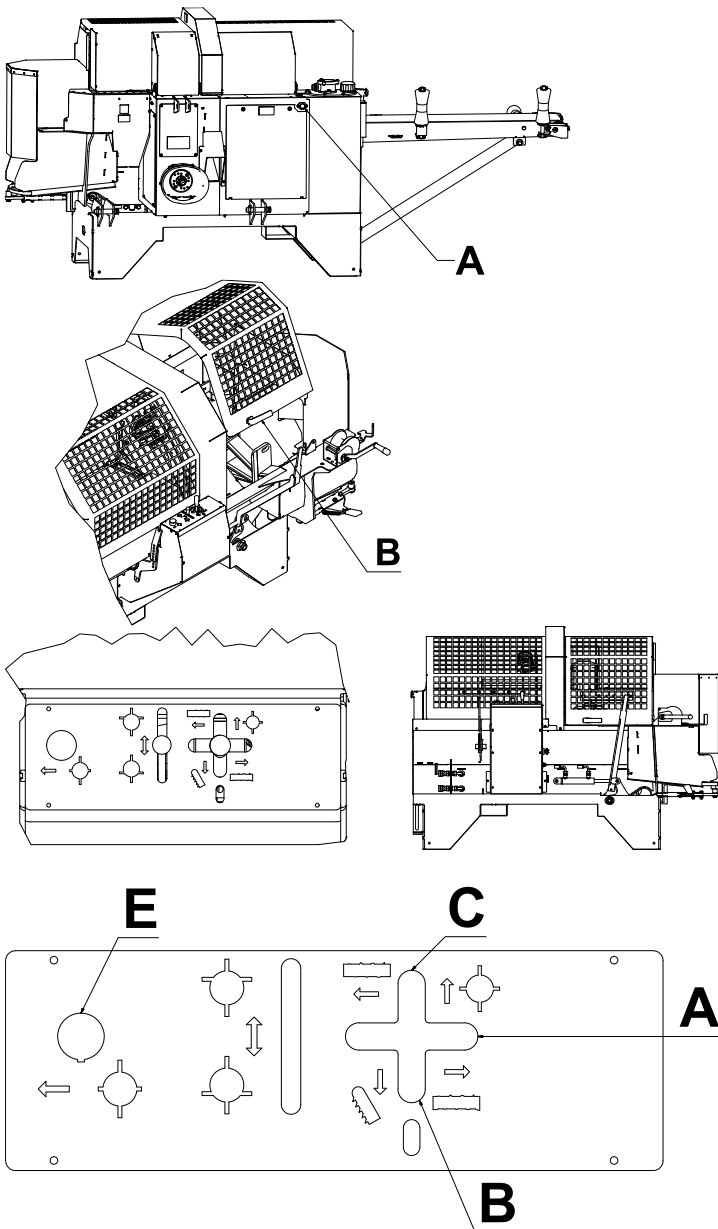

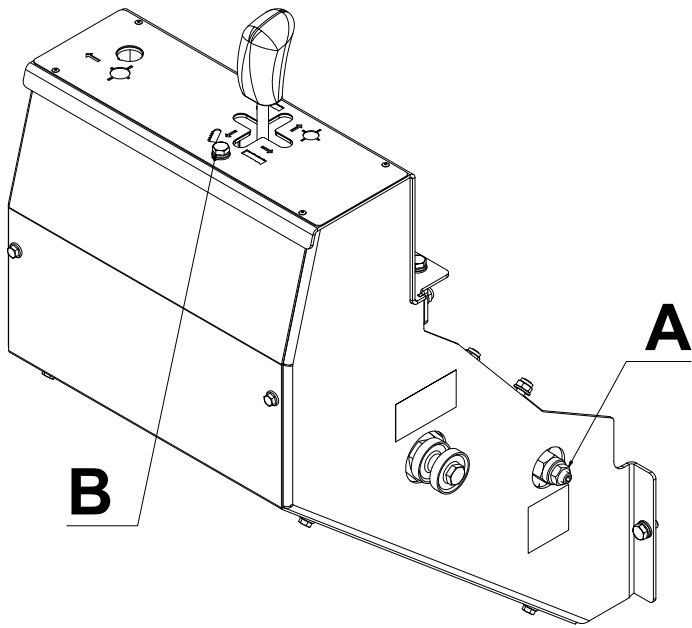

### Adjustment of cutting

In order to adjust the cutting operation in the very best way to material both speed and sword pressure can be adjusted..

The downward speed of the sword are adjusted by the joystick during cutting. Adjusting the screw B maximum movement level can be reached.

The sword pressure can be adjusted by the screw marked A

Start with low pressure and adjust upwards. Too low pressure might stop the saw bar from moving to the «bottom» level.

Too much pressure can harm the motors pull ability and engage the safety valve .

Rotating the screw into the machine the pressure drops.

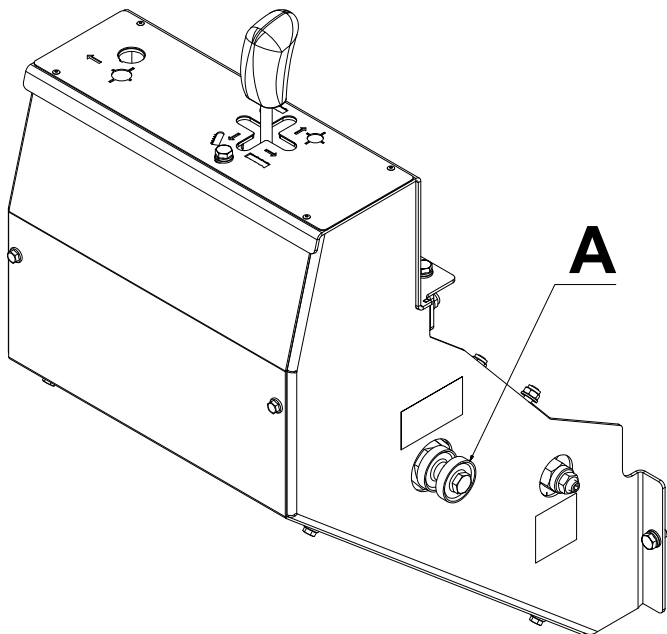

### Speed output conveyor

The speed is adjusted with an adjustment wheel fitted on the adjustment block for this at letter A as illustrated.

Select a speed that suits the purpose – depends on the desired throwing length and container to receive the wood. Avoid that the wheel bites-locks into the aluminium.. It is advised to loosen the wheel when the machine is not used.

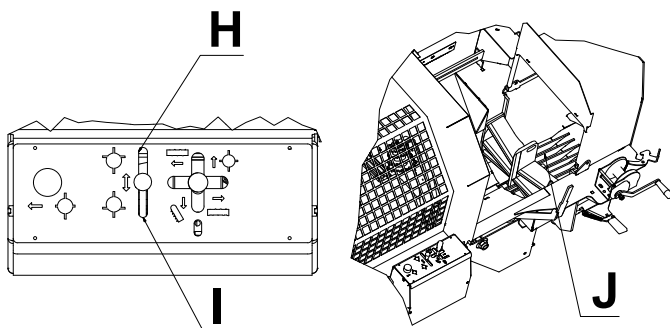

### Hydraulic knife lift

The splitting knife H is adjusted up H and down I with the lever equipped for this purpose

In order to change knife J, the lever is moved to the top position (H). In this position, release the locking pin keeping the knife in position and lift out

This is valid for VM370X-model

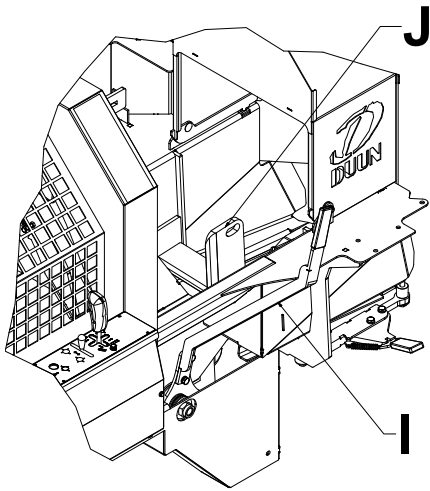

### Manual knife lift

The splitting knife **J** is up- and downwards adjusted by pushing the handle **I** to the left or right.

Release the locking pin keeping the knife in position and lift out

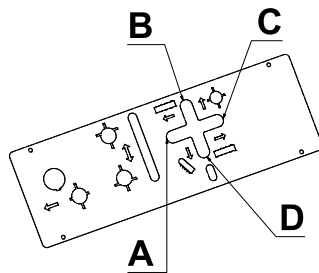
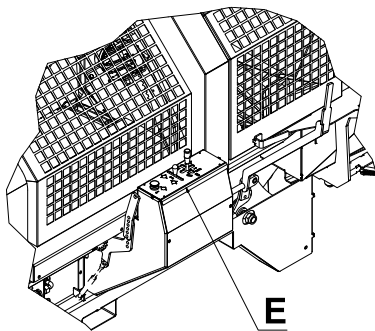

### Cutting

The lever for operating cutting and operation of the feeding conveyor forwards and backwards (**E**) has several functions:

The saw chain is hydraulically operated and starts when the lever is moved towards (**D**).

The lever also releases the splitting function when it is moved towards (**B**) as illustrated.

### Thin wood material that is not to be split

When cutting thin wood materials, you may cut several continuous lengths and let them fall into the splitting cradle without activating the splitting piston. This makes for a far faster cycle.

The splitting function is always released by moving the cutting lever to position **B**.

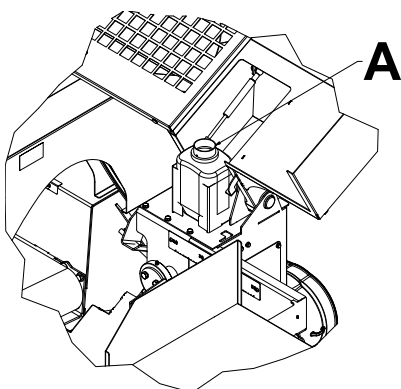

### Filling saw chain oil

The processor has a separate container **A** for chain oil.

The chain is greased at every cut movement and it is very important to supply oil before the container is empty. Regular saw chain oil for chainsaw use to be applied..

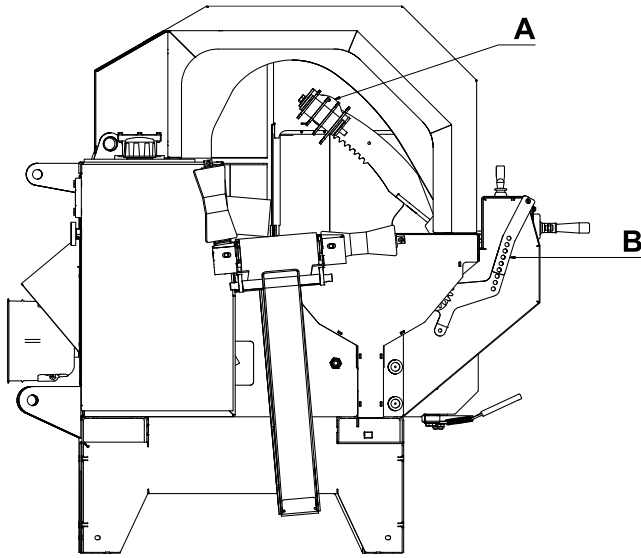

### Safety hand operated log holder

Avoid placing your hands close to the saw chain. This is obtained by using the log holder B and the handle A to operate it.

For cutting the last log of wood, it is important to retain a "suitable" length and cut a shorter piece as the next to last. During this operation, it is especially important to use the hand operated log holder B by means of the handle A so that the user does not receive an unexpected backlash from the final piece.

**When you want to cut twiggy or crooked logs, it is important to make sure that these are securely placed. Use the hand operated log holder as much as possible during cutting of such wood materials to prevent that fingers/hands are squeezed**

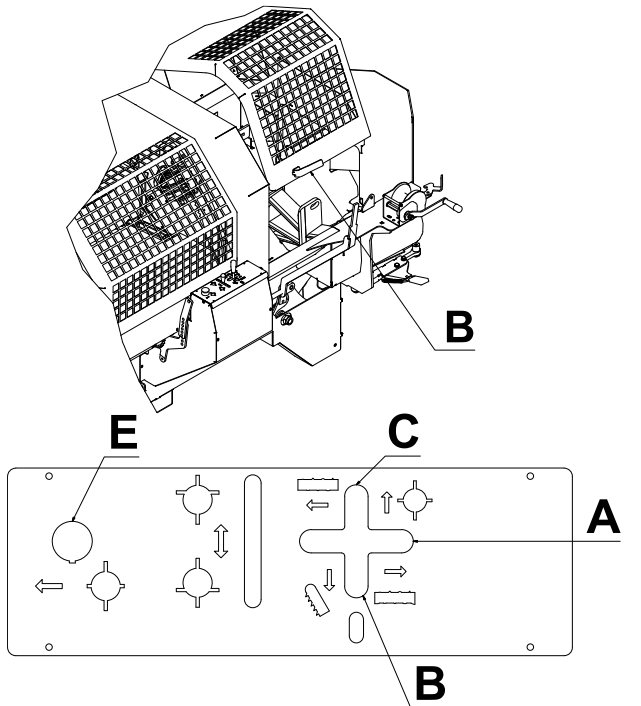

### Jammed wood materials

If the splitter does not manage to split the wood – the piston is moved backwards by activating the knob E , or opening the lid B making the splitter stop.

The log must be removed manually. Close the safety cover B and push knob E resetting the splitters function. The log may be introduced again for another attempt.

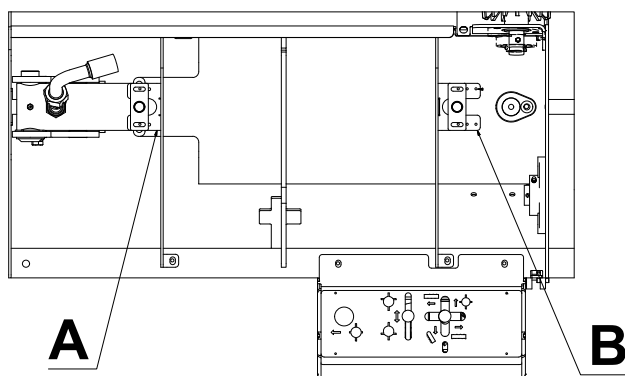

The stop signal and the return signal for the splitter is performed by two magnetic valves. These contact points can be adjusted by the positioning of the magnetic valves to their brackets..

Magnetic valve A adjusts the stop signal. Magnetic valve B adjusts the return signal. It is important that the cylinder does not move completely to each end!.

# Chain sharpening and tightening

## General

Blunt chains and skewly sharpened chains entail great wear on the saw chain sword and risk of extra costs and complications.

In order to avoid this, Duun VM370 is designed so that the saw chain always must be dismantled from the machine for any sharpening or replacement.

As a starting point, we recommend replacement of the chain or sharpening in equipment designed for this purpose.

Alternatively, the saw chain may be sharpened in accordance with the standard procedure with a file with file gauge for 4,8mm chain and rider gauge. This is to safeguard against faulty sharpening and complications.

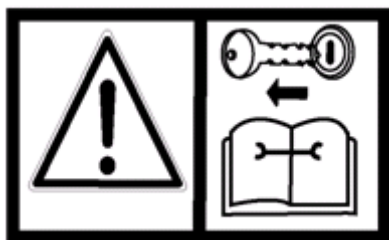

Before any sharpening work is initiated – stop the machine and tractor and remove the key to ensure unintentional start during the work

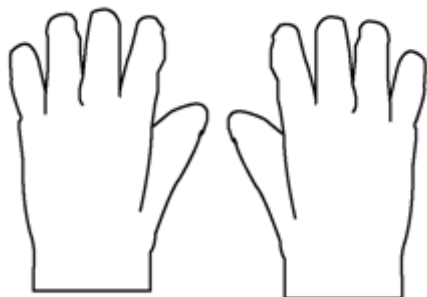

Always use work gloves during work with the chain!

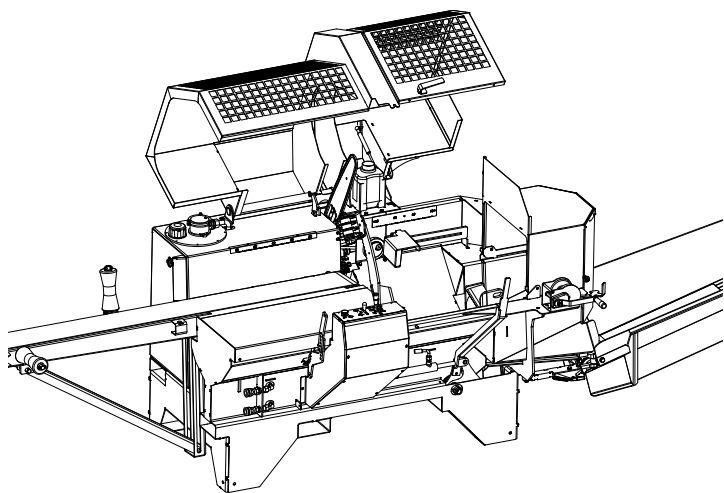

The covers over the chain bar and the cover over the splitting cradle can be opened as illustrated

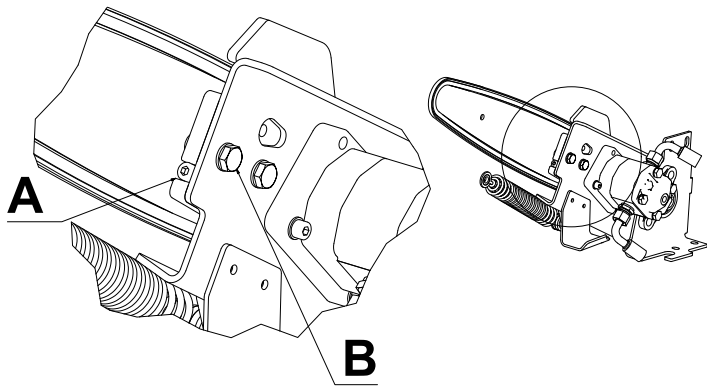

To replace the chain both screws **B** are loosened. The screw **A** is released so far that the saw chain can be hitched off for maintenance or replacement.

In order to tighten the chain the loosened screws **B** are still loose and screw **A** is tightened.

Then screws **B** are tightened.

Inspect the tightening by pulling the chain upwards at the middle of the saw bar. If you can stretch the chain 4.5mm upwards the tightening is correct.

A new saw chain elongates rapidly and must be frequently inspected.



File dimension 4,8 mm

The chain is now available for sharpening with a round file from both sides. It is very important to maintain the correct shape of the teeth as illustrated. The main concern is to employ the correct file dimension and make sure you maintain the correct angle of the cutting edge – i.e. 30 – 35 degrees. Figure F shows the correct shape of a sharpened tooth.

Also remove damages from the saw bar and turn the saw bar regularly. This in order to achieve even wear on both sides.

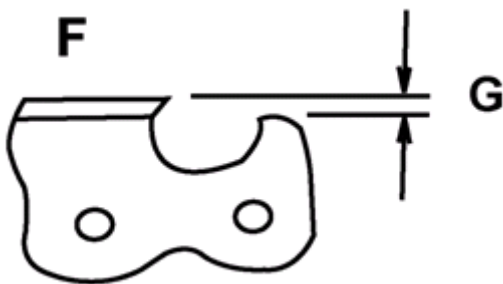

## 2 Adjustment of the chain lubrication

The need for chain lubrication may vary with the average thickness of the wood material.

The lubrication is adjusted by releasing the connection (D) and turning the eccentric disk clockwise (+) to increase the lubrication quantity per blow or the opposite (-) to reduce the

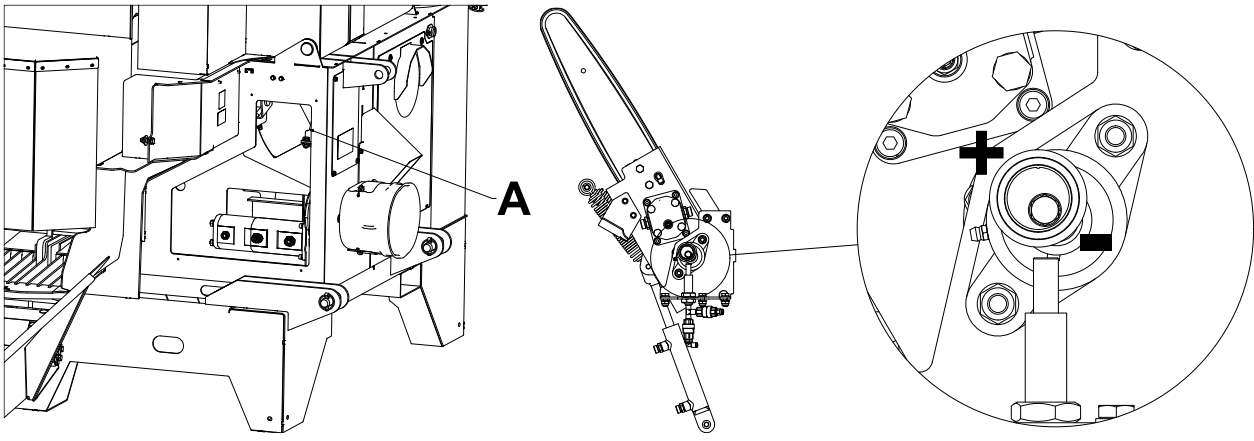



# Service and maintenance

Before opening any lids or covers always stop tractor or motor powering the processor in order to avoid injuries

**Please note:**

**There are movable parts inside the machine which involve great power and risk of crushing. The machine should never be operated when the covers are removed.**

The processor has been test run and adjusted from factory and the hydraulic oil should have reached a working temperature of minimum 20 degrees C before any adjustments are made.

## Everyday maintenance inspection

Keep a clean and tidy environment around the machine. To ensure good function the processor need open space under and get rid of saw chips.

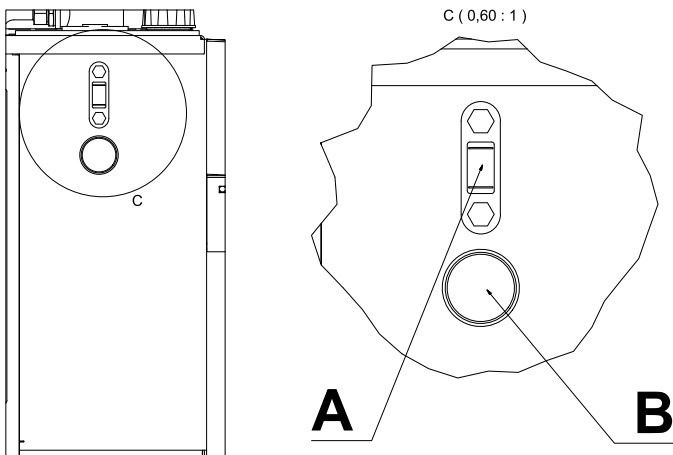

Inspect oil level and hydraulic oil temperature regularly. Refill oil if necessary  
Correct oil level should be in the middle of level glass **A** when placed at horizontal level

The temperature **B** should never be higher than +70 degrees C.  
If the temperature reaches critical level the pto speed should be reduced. NB max. 400 rpm.

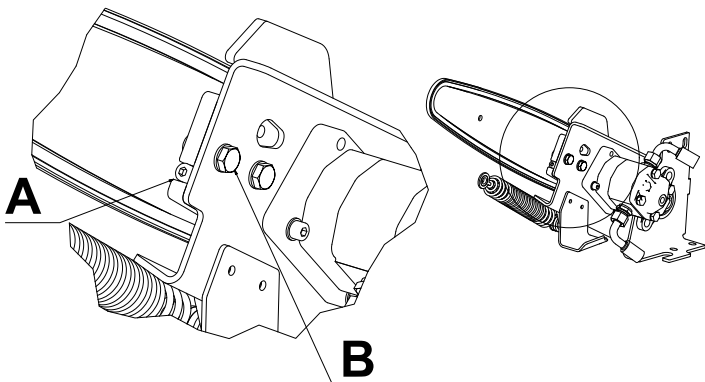

Inspect cutting chain and saw bar regularly. Sharpening and tightening of the saw chain ensure effective cutting. Check that the vertical angle of the saw bar (90 degrees) so that the saw bar does not jam during cutting.

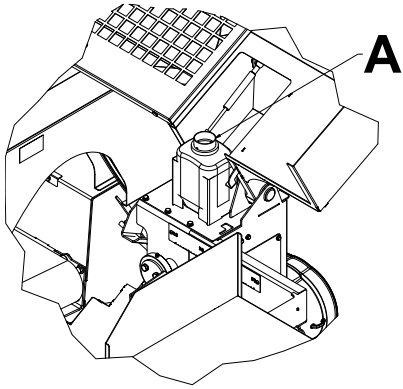
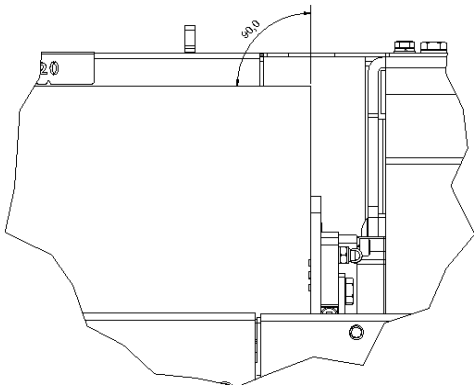

Ensure that the chain oil container does not drain during use. Also inspect that oil is consumed and the chain lubricated..

### Weekly maintenance

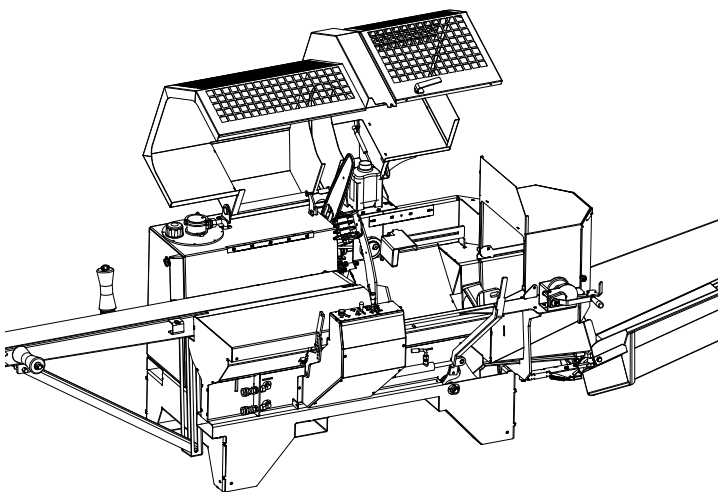

Open all lids and safety covers and clean these (compressed air). Avoid that the oil tank is covered by dust and chips. This in order to keep up a best possible cooling effect and perfect functions all the time..

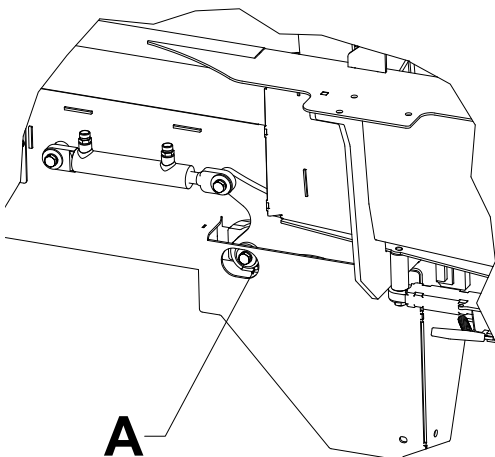

Grease the knife gauge **A**

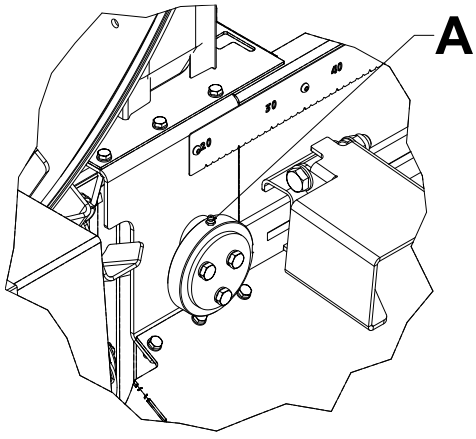

Grease the log stopper **A**

## Monthly maintenance

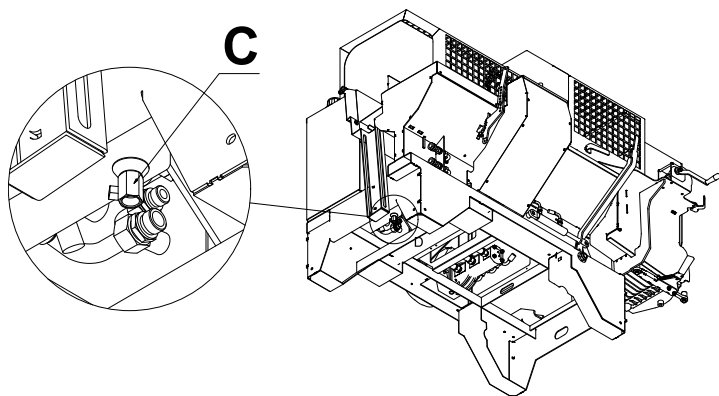

Regularly drain a small amount of hydraulic oil **C** to check the oil quality. Grey oil is an indication of water in the oil caused by condensation. Perform this inspection when the machine is cold and eventual water concentrated at bottom level. Drain till clean oil comes out. All oil to be replaced.

## Yearly maintenance

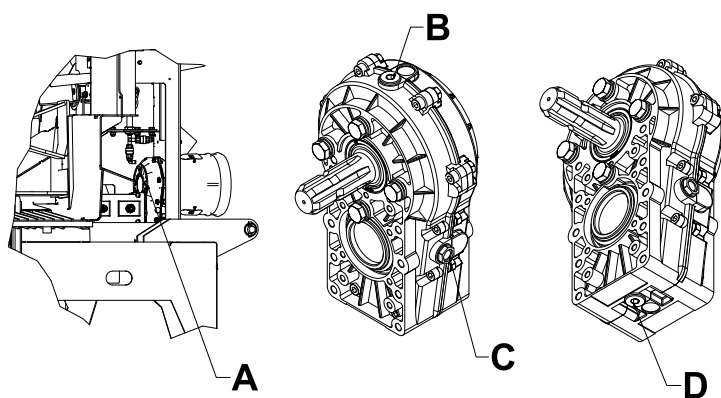

Check the oil level after each season by releasing level screw **C** as illustrated in the sketch (the oil to leak at sufficient level). Replacing oil via the breathing plug **B** on the top and the drainage via the plug **D**. The first oil change to be performed after 50 hours and then every other season or after 500 operating hours (whatever occurs first). Recommended oil: Statoil Gearway PS45 75-90 Specification API GL-5 or similar. The oil volume is 0.35 litres.

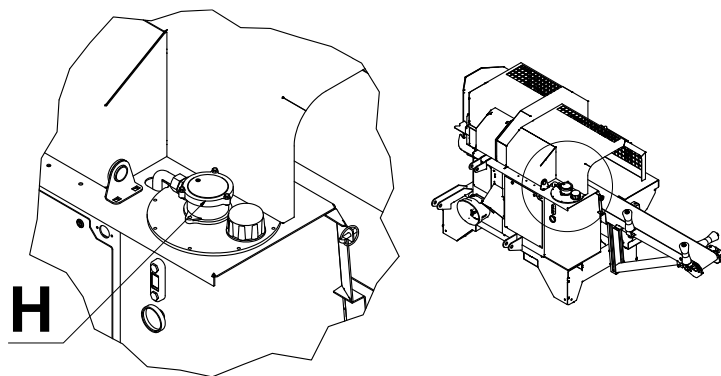

Replace the Filter cartridge **H** in the oil filter (1) after the first 50 operating hours and afterwards once a year or after 500 operating hours (depending on whatever occurs first)

Change hydraulic oil after the first 50 operating hours and later every year or after 500 operating hours (whatever occurs first).

Filter cartridge, SIF.20C10  
Item No. 2251065

Clean and lubricate the machine between each season.

The VM370 has many lubrication points. Many of these have a very light load and are equipped with «forever» greased bearings.

Other bearings are mainly flange mounted ball bearings demanding very modest greasing. The main rule to avoid excessive greasing and damage to seals for the bearings.

## Declaration of conformity

### Responsible person

Name: Roar Størseth  
Position: Factory manager  
Company name: Duun Industrier as  
Address: N-7630 Åsen  
Norway  
Telephone: +47 74 01 59 00



Person responsible for the technical documentation: Rolf Even Duun

Declares that the following machine: VM370 Firewood processor  
Manufacturer: Duun Industrier as  
Type: Duun Firewood processor VM370  
Production year: 2016  
is in accordance with:

Direktiv 2006/42/EC Machinery

Signed by:

A handwritten signature in blue ink, reading 'Roar Størseth', written over a horizontal line. A faint, semi-transparent stamp of the Duun Industrier logo is visible behind the signature.

Roar Størseth

Åsen, 07.01.2016